

Prescribing Transformer for Medical Electronic Systems

Part I: Introduction

Medical systems are designed according to extremely demanding requirements. Guided by such regulatory organizations as Underwriters Laboratories (UL) and the International Electrotechnical Commission (IEC), electronics for medical use must be designed for safety, for minimal interaction with other electronic devices, and for military-grade reliability. Because of this, virtually all components of medical electronic products, as well as the end products themselves, must be designed with safety in mind. In specifying transformers for the power electronics in medical systems, designers should be aware of some of these requirements to ensure that proper choices are made.

In the United States, product safety compliance is mandated by the Occupational Safety and Health Administration (OSHA). Created in 1970 to police the American workplace for safety and health issues, OSHA adopted regulations requiring any form of equipment using electricity to be listed with it. The act of being listed or certified with OSHA can help a manufacturer of electronic devices avoid criminal, civil, and private legal actions. OSHA appoints laboratories such as UL to test and certify electronic equipment according to its requirements.

Similarly, the IEC is viewed by most European nations as their standards-setting organization, with testing and certification performed according to the national laboratory of a particular nation, such as the Verband Deutscher Elektrotechniker (VDE) in Germany. Safety standards attempt to create two levels of protection within an electronic device, based on the assumption that any one level of protection may be compromised over the life of the device. In the case of medical equipment, the safety of both the operator and the patient must be ensured.

Transformers are often taken for granted by designers of medical systems because of their simplicity. But such an assumption can prove disastrous during compliance testing by an organization such as UL. Once a transformer is embedded within a design, it can be difficult to trace as the mechanism that might cause a failure during compliance testing. A failure to meet compliance results in the manufacturer of that product having to perform a time-consuming and expensive redesign, losing valuable time to market and market share. A better approach involves careful attention to the requirements of the medical safety standards early in the design cycle, to prevent delays at a later date.

Specifically, electronic products designed for medical use must conform to UL 544/UL 2601 in the United States and the IEC-601-1 (EN60950) in Europe. The goal of these standards is to ensure that all medical electronic products provide a high level of safety for the operator and the patient. In North America, the primary focus of standards-setting agencies is fire safety; for European organizations, it is the prevention of electric shock. In countries adopting IEC-601, this is understandable, since line voltages may reach as high as 260 V, typically twice that found in North America.

The UL 544 and IEC-601 standards are both written as end-product specifications, rather than guidelines for component compliance. Still, they do contain requirements for the transformer as part of the total system. A designer's main job in accommodating these standards is to ensure safe placement and proper isolation of the transformer within the medical system.

For example, the power supply should be mounted in such a way as to minimize the length of power-line cord that is exposed within a product design. The power-line cord can act as an antenna to pick up and reradiate radio-frequency interference (RFI). The use of a line filter or a ferrite bead mounted near where the line cord enters the chassis of the electrical equipment can attenuate unwanted signals and prevent their radiation.

Prescribing Transformer for Medical Electronic Systems

Part II: Reviewing the Standards

Underwriters Laboratories' UL 544 standard is intended to maintain a satisfactory level of performance for all electrical and electronic medical and dental equipment used in homes and by professionals in hospitals, nursing homes, medical-care centers, and medical/dental offices. The standard applies to portable equipment rated at 300 V or less and permanently connected equipment rated at 600 V or less.

While some types of medical equipment, such as x-ray systems, heating pads, and refrigerated medical equipment, are not covered by UL 544, the majority of medical equipment is covered by UL 544. The standard specifies different requirements for equipment that is not used by or connected to patients, and for equipment that is connected to a patient. The UL 544 standard specifically addresses the requirements of power-supply transformers, and is accepted as the safety conformance standard for the United States.

The International Electrotechnical Commission's IEC-601 is formally known as the "International Standard, Medical Electrical Equipment." Adopted by most European countries, it is also gaining favor among nations throughout other parts of the world. The standard directly covers transformers in a manner similar to UL 544, and also concentrates on the characteristics of the end product. In certain areas, IEC-601 is even more stringent than UL 544 in its compliance requirements.

The IEC-601 standard differs from UL 544 primarily in the type and requirements of some of its tests, such as the required physical separation of the primary and secondary windings in a transformer. Due to these construction constraints, both standards mandate the use of a 0.005" minimum thickness copper screen for concentrically wound coils. (Fig. 1)

Fig. 1 - Nonconcentric winding construction

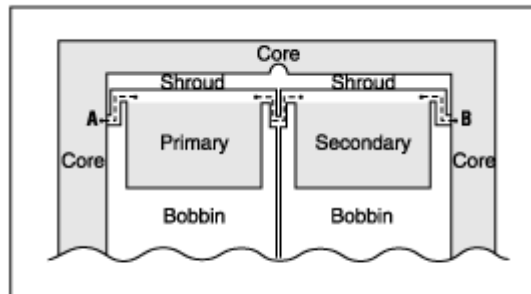

This cross-sectional view shows creepage distances between a transformer's primary and secondary windings, and from the transformer's windings to its core.

The overall requirements for transformers used in medical electronic equipment fall into five categories: leakage current, high-pot, construction requirements, temperature class, and current and thermal fusing. Additional concerns, such as electromagnetic compatibility (EMC) and physical location, affect how a transformer is designed into a system, but such concerns are addressed in other areas of the standards and are more directly related to the end product rather than the transformer.

Leakage current is the amount of current that leaks from windings to core and from windings to windings when voltage is applied to the transformer. Ideally, the amount of current would be zero, but realistically, the lowest possible current flow is preferred. Both UL 544 and IEC-601 state maximum acceptable leakage currents, typically 100 mA. In a case where the equipment, minus the transformer, has leakage current of 50 mA, a maximum allowable leakage current of 50 mA can be attributable to the transformer (for those cases where the limit is 100 mA). A transformer's leakage current can be

Prescribing Transformer for Medical Electronic Systems

tested with a simple measurement system (Fig. 2).

Fig.2 - Leakage current test setup

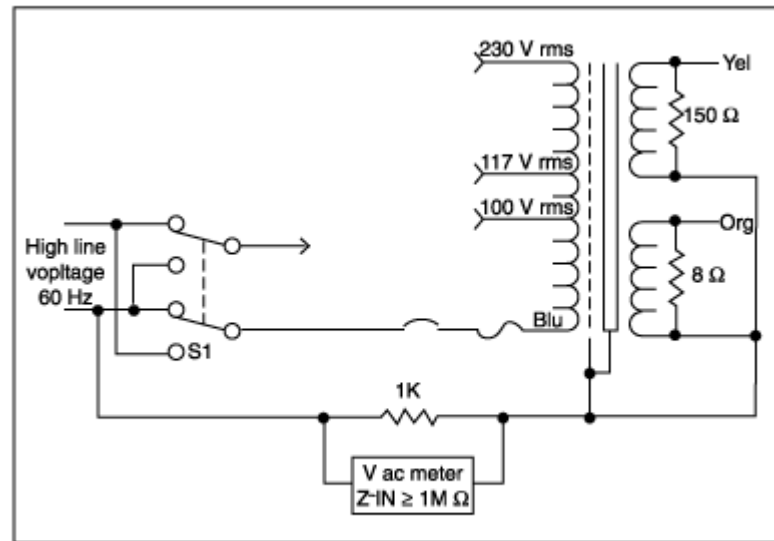

This simple measurement system can be used to evaluate transformer leakage currents.

Both UL 544 and IEC-601 require evaluation of a transformer after abnormal conditions. A high-pot test is usually performed after a transformer is subjected to unfavorable or “abnormal” operating conditions, such as having one secondary winding shorted out and the other operating under full load.

High-pot testing is intended to stress the coil’s insulation system to detect a potential fault. Although UL 544 and IEC-601 differ somewhat in their requirements, a typical test voltage for UL 544 will be 1500 V for a 230 V primary, whereas a typical test voltage for IEC-601 is 4000 V for the same primary voltage.

Other demanding tests defined by these standards are designed to simulate real-world fault conditions. The abnormal tests such as short-circuit and overload/ overheating tests can result in the catastrophic failure of an unprotected transformer. If during the execution of these tests, observed temperature rises exceed the maximum allowable limit for a given insulation system, the transformer will fail to meet the requirements. Transformers that fail these tests may have otherwise passed if circuit protection had been incorporated.

Two types of fuses are utilized in electronic equipment: overcurrent and thermal types. Overcurrent fusing is required in every medical electronic product. Circuit protection may be in the form of either, current, thermal, or a combination of each. Thermal protectors, while designed primarily for thermal sensing with either single or multiple activation (auto resetting), may also have current limit thresholds. Current protectors may also be single-operation devices (fuses) or auto- or manual-resetting circuit breakers. Guidelines for circuit protection characteristics are defined within the standards.

Testing transformers with overcurrent fuses is straightforward. When determining the maximum output current of a fuse-protected winding, the accessible device is either removed and replaced with a device of negligible impedance or it is shunted. Overheating tests are performed in a similar manner but with the load current being increased by a predetermined factor based on the fuse rating.

Located external to the transformer, overcurrent fuses are placed in series with the primary and

Prescribing Transformer for Medical Electronic Systems

secondary windings. They must be rated with a high enough value to handle in-rush currents, but with a low enough value to protect against short circuits in the transformer. The rated current value for a primary overcurrent fuse is generally 1.25 to 1.5 times the maximum full-load current and a secondary overcurrent fuse is usually 2.5 times the full-load current.

To determine the steady-state root-mean-square (RMS) current on the primary winding, a true RMS ammeter should be placed in series with the primary winding. Measurements should be made of worst-case current values under low-line and high-line conditions. If the product is rated for 50 or 60-Hz operation, the test should be performed at high-line 50 Hz, at which the transformer's losses will be greatest.

Although a transformer can pass UL 544 and IEC-601 tests without a thermal breaker, the inclusion of this type of fuse can provide an extra measure of safety and insurance for compliance testing. Such circuit breakers are tamperproof and can effectively cut off voltage during short-circuit conditions. As a supplemental fuse to an overcurrent fuse, a thermal breaker interrupts current flow and creates an open circuit (shutting the system down) if a transformer gets too hot.

Both self-resetting and nonresetting thermal breakers are available. In contrast to overcurrent fuses, which are located outside a transformer, thermal breakers are located within the transformer, usually over, under, or between primary windings (Table 1). Nonresetting thermal breakers require a transformer to be replaced for equipment operation to resume. Self-resetting thermal breakers restore current flow when the temperature drops to an acceptable level.

Table 1. – Shows maximum allowable temperature rise for various types of insulation.

Type of Protection	°C Maximum		°C Maximum	
	Class 105 or A Insulation	Class 130 or B Insulation	Class 105 or A Insulation	Class 130 or B Insulation
Impedance	135	160	-	-
Thermal Cut-Out Automatic Reset				
1. During first hour of operation	175	200	-	-
2. After first hour of operation	150	175	125	150
Manual Reset				
1. During first hour of operation, or during the first 10 cycles of operation mentioned in paragraph 34.17, whichever is the shorter interval	175	200	-	-
2. After first hour of operation if the first 10 cycles of operation mentioned in paragraph 34.17, require more than 1 hour for completion	150	175	-	-
Fusible and Nonresettable Device				
1. Before opening during first hour of operation	175	200	-	-
2. Opening after first hour of operation	150	200	-	-

Prescribing Transformer for Medical Electronic Systems

According to UL 544 and IEC-601 requirements, a power-supply transformer must be carefully isolated in medical equipment to ensure safe operation. Perhaps the easiest way to ensure compliance is by working closely with a transformer manufacturer, who has the experience and knowledge of the design and testing issues required by these safety standards.